

Features

- Four wire system
- Piezoresistive measuring element
- Output signal 4-20 mA and RS-485
- Analogue output adjustable within 1 : 4 of the original measuring range
- RS-485 interface with Modbus RTU protocol
- Conformity error $\leq \pm 0.1$ % FS, option $\leq \pm 0.05$ % FS
- Standard DIN measuring ranges from 0 ... 100 mbar up to 0 ... 25 bar or selection of measuring ranges in mWC or psi
- Temperature compensation within $-10^{\circ}\text{C} \dots +50^{\circ}\text{C}$ [$+14^{\circ}\text{F} \dots +122^{\circ}\text{F}$]
- Temperature output
- Optional overvoltage (lightning) protection according to EN 61000-4-5
- Compact and robust

Picture



Specifications

Unless otherwise stated, all specifications are at supply voltage 24 V DC, $R_L = 100 \Omega$ and 25°C [77°F] operating temperature.

Measuring Range Independent Technical Data

Type	4-wire current transmitter
Analog output signal, pressure	4 ... 20 mA
Resolution	12 bit (< 0.025 % FS)
Digital output signal (pressure and temperature) Protocol details	RS-485 Modbus RTU, 9600 bps see Data Sheet SW 21.220.1560205.001
Analog output signal, temperature	4 ... 20 mA
Measuring range	$-10^{\circ}\text{C} \dots +50^{\circ}\text{C}$ [$+14^{\circ}\text{F} \dots +122^{\circ}\text{F}$]
Resolution	0.1°C [0.18°F]
Accuracy of temperature measurement	$\leq \pm 1^{\circ}\text{C}$ [$\pm 1.8^{\circ}\text{F}$] in entire temperature measuring range
Interface for adjustment Protocol details	RS-485 Modbus RTU, 9600 bps see Data Sheet SW 21.220.1560205.001
Output 0% adjustability	-5% of original FS ... +105% of original FS
Output 100% adjustability	-5% of original FS ... +105% of original FS
Difference (0% - 100%) adjustability	$\geq 25\%$ of original FS and ≥ 50 mbar [0.725 psi]
Damping adjustability	~ 33 ms (default), 100 ms, 1 s, 10 s = 30 Hz (default), 10 Hz, 1 Hz, 0.1 Hz cut-off frequency

Supply voltage	DC 9 ... 30 V
Reverse polarity protection	Integrated, standard
Overvoltage protection (lightning protection)	Option
Supply voltage influence	< 0.1 % FS
Current consumption (requirement without 4 ... 20 mA outputs, without RS-485 load)	≤ 20 mA
Maximum voltage housing / supply	500 V
Permitted load	see paragraph "Cable Lengths"
Load influence	< 0.1 % FS
Protection class	IP68 (~NEMA 6P)
Medium temperature range	-5°C ... +50°C [+23°F ... +122°F]
Temperature compensation range	-10°C ... +50°C [+14°F ... +122°F]
Storage temperature range	-10°C ... +50°C [+14°F ... +122°F]
Acid resistance	pH5 ... pH9
Weight	Approx. 200 g [0.441 lb] without overvoltage protection Approx. 280 g [0.617 lb] with overvoltage protection plus approx. 260 g [0.573 lb] with weight extension
Measuring cell, membrane, housing	Stainless steel 1.4435 (316L)
Seals	Viton
Cable	Choice of PE / PUR / FEP cable with integrated pressure equalising pipe
Outer diameter	6 mm [0.24"] PE / PUR; 5 mm [0.2"] FEP
Leads	0.22 mm ² [AWG 24], Cu wire 7 x 0.20 tinned
Resistance	≤ 82.9 mΩ/m [25.3 mΩ/ft] (one conductor)
Minimum cable bending radius	100 mm [4"]
Tensile load	< 400 N [90 lbf] (PE / PUR cables) < 15 N [3.4 lbf] (FEP cables)
Tensile strength	> 500 N [112 lbf]
Pressure equalising pipe diameter	Ø 1.4 / 0.8 mm [0.055" / 0.03"] PE / PUR; Ø 1.1 / 0.6 mm [0.04" / 0.02"] FEP
PE cable (foodstuffs approved / drinking water)	
Permitted environmental temperature	-20°C ... +70°C [-4°F ... +158°F]
Weight	Approx. 41 g/m [0.44 oz/ft]
PUR cable (mechanically robust)	
Permitted environmental temperature	-20°C ... +95°C [-4°F ... +203°F]
Weight	Approx. 45 g/m [0.48 oz/ft]
FEP cable (high temperature range)	
Permitted environmental temperature	-40°C ... +90°C [-40°F ... +194°F]
Weight	Approx. 55 g/m [0.59 oz/ft]
Electromagnetic Compatibility	
Emissions	
Basic specification emissions	EN 61000-6-3
Emissions class B	EN 55022
Immunity	
Basic specification noise immunity	EN 61000-6-2
Electrostatic discharge	EN 61000-4-2 (4 kV contact, 8 kV air)
Radiated electromagnetic field	EN 61000-4-3 (10 V/m, 80 ... 1000 MHz, 80% AM 1 kHz)
Radiated electromagnetic field (GSM)	EN 61000-4-3 (10 V/m, 950 MHz, 200 Hz on/off)

Fast transients (burst)	EN 61000-4-4 (2 kV)
Conducted electromagnetic interference	EN 61000-4-6 (10 V/m, 0,15 ... 80 MHz, 80% AM 1 kHz)
Impulse voltage (surge)	EN 61000-4-5 (10 kA 8/20µs)
	[only with the option overvoltage (lightning) protection]

Quality Tests

CE The transmitters fulfil the requirements for noise immunity and emissions of the EMC directive 89/336/EEC.

Measurement Range Dependent Technical Data

Pressure ranges	< 0.2 bar [2.9 psi]	≥ 0.2 ... 1 bar [2.9...14.5 psi]	≥ 1 ... 25 bar [14.5...362.6 psi]
Overload	3 bar [43.5 psi]	3 bar [43.5 psi]	3 x FS
Bursting pressure	> 200 bar [2900 psi]	> 200 bar [2900 psi]	> 200 bar [2900 psi]
Conformity error incl. hysteresis and repeatability -5°C ... +50°C [+23°F...+122°F] Option for pressure ranges ≥ 1 bar	≤ ±0.2 % FS ---	≤ ±0.1 % FS ---	≤ ±0.1 % FS ≤ ±0.05 % FS
Temperature error zero / span -10°C ... +50°C typ. [+14°F...+122°F] max.	≤ ±100 ppm FS/°C ≤ ±150 ppm FS/°C	≤ ±60 ppm FS/°C ≤ ±100 ppm FS/°C	≤ ±60 ppm FS/°C ≤ ±100 ppm FS/°C
Long term drift typ.	≤ 0.2 % FS/a	≤ 0.2 % FS/a	≤ 0.1 % FS/a

Dimensions [mm]

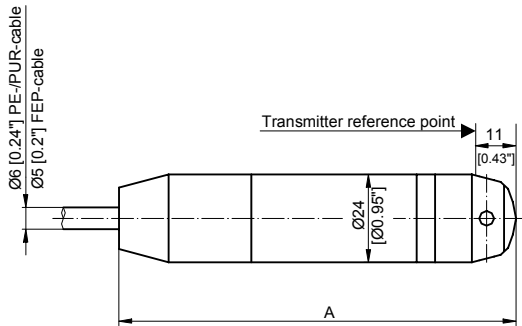

Closed version (standard):

A = 157 mm [6.2"] without overvoltage protection
 A = 258 mm [10.2"] with overvoltage protection
 Plus 87 mm [3.4"] with weight extension

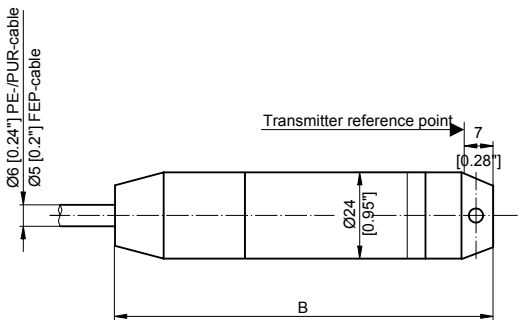

Open version:

B = 153 mm [6.0"] without overvoltage protection
 B = 254 mm [10.0"] with overvoltage protection
 Plus 87 mm [3.4"] with weight extension

Ordering Information

Table 1:

The precise designation for an article is derived from the combination of the individual option codes according to the table (with the BAAN configurator PCF or manually).

MPC	PCF Order Number																
	1/2	3	4	5	6	7	8	9	10	11	12	13	14	15	16		
Type																	
MPC	PC																
Pressure Type																	
Relative		1															
Measuring Range																	
0 ... 100 mbar = 0 ... 1.45 psi			0	0													
0 ... 160 mbar = 0 ... 2.32 psi			0	1													
0 ... 250 mbar = 0 ... 3.63 psi			0	2													
0 ... 400 mbar = 0 ... 5.8 psi			0	3													
0 ... 600 mbar = 0 ... 8.7 psi			0	4													
0 ... 1.0 bar = 0 ... 14.5 psi			0	5													
0 ... 1.6 bar = 0 ... 23.2 psi			0	6													
0 ... 2.5 bar = 0 ... 36.25 psi			0	7													
0 ... 4.0 bar = 0 ... 58 psi			0	8													
0 ... 6.0 bar = 0 ... 87 psi			0	9													
0 ... 10 bar = 0 ... 145 psi			1	0													
0 ... 16 bar = 0 ... 232 psi			1	1													
0 ... 25 bar = 0 ... 362.5 psi			1	2													
0 ... 1 mWC			6	0													
0 ... 2 mWC			6	1													
0 ... 5 mWC			6	2													
0 ... 10 mWC			6	3													
0 ... 20 mWC			6	4													
0 ... 50 mWC			6	5													
0 ... 1.5 psi			7	0													
0 ... 3.0 psi			7	1													
0 ... 7.5 psi			7	2													
0 ... 15 psi			7	3													
0 ... 30 psi			7	4													
0 ... 75 psi			7	5													
0 ... 150 psi			7	6													
0 ... 300 psi			7	7													
Special calibration (always > 0 ... 100 mbar)			9	9													
Version																	
Closed, standard (membrane protected)					5	5											
Open					5	6											
Electrical Connection																	
PE cable (foodstuffs approved)							1	3									
PUR cable (robust)							1	5									
FEP cable (large temperature range)							2	1									
Output Signal																	
4 ... 20 mA P & T & RS-485 without overvoltage protection									6	5							
4 ... 20 mA P & T & RS-485 with overvoltage protection									6	6							
Accuracy																	
±0.2 % FS, only for measuring ranges < 200 mbar												4					
±0.1 % FS, only for measuring ranges ≥ 200 mbar												2					
±0.05 % FS, only for measuring ranges ≥ 1 bar												6					
Temperature Range																	
Compensated -10°C ... +50°C (medium -5 ... 50°C)												4					
Cable Length																	
Cable length in metres (always ≥ 001)															x	x	x

Parameterisation

With the aid of the programming kit MPPKIT available as an accessory, the software of the submersible transmitter can be parameterised with a PC (see also Data Sheet 21.210.0066900.001 and Operating Instructions 21.810.0066900.001).

- Range selection for output current 4 ... 20 mA

With the range selection 4 ... 20 mA, the 4 mA and 20 mA current values can be assigned to measured values other than the standard 0% and 100% of the nominal measuring range. (Typically with 4 mA a value from the range -5% ... +25% of the nominal measuring range, with 20 mA, a value from the range +25% ... +105% of the nominal measuring range.) In this way, a sub-range, even a negative pressure can be measured. The difference Δ between the minimum and maximum must amount to at least 25% of the nominal measuring range and be at least 50 mbar.

Inverted control can be achieved by exchanging the values for 4 mA and 20 mA.

The ranges of adjustability are presented graphically in the following illustrations.

Non-inverted Control:

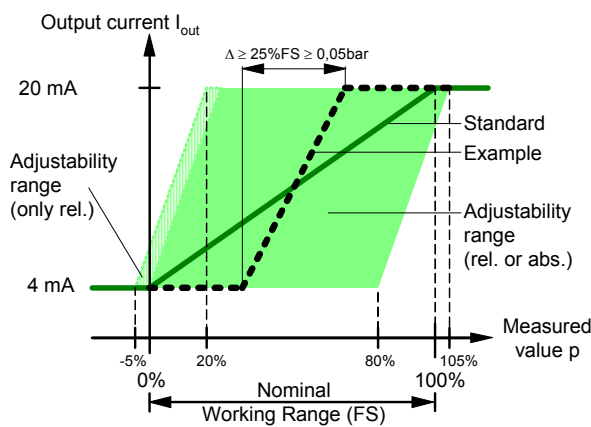

Inverted Control:

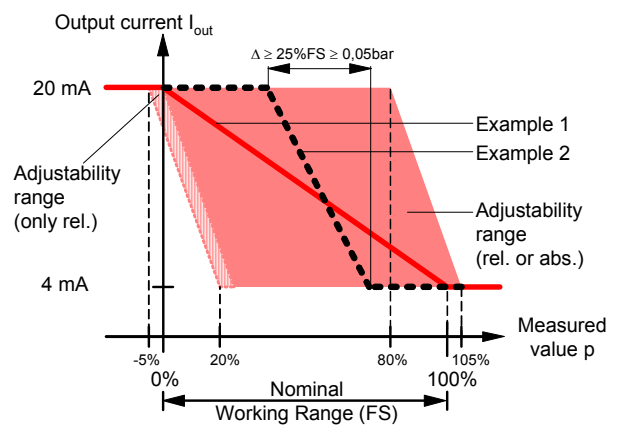

- Programmable Damping of the Current Output

The analog output can be damped with a low pass filter of the 1st order. The adjustability enables values between ~ 33 ms (default) and 10 s.

Note: During commissioning, damping is preferably left at the minimum value.

- Recalibrating the transmitter (calibration 0 % or 100 %) enables compensation of the drift which inevitably occurs with resistive pressure transducers. The zero drift alone or the combination of zero drift and slope change can be compensated. In doing so, the original calibration of the transmitter is not lost and can be recalled as necessary.

Setting range 0%: -5% ... +5% of nominal measuring range (FS)

Setting range 100%: 95% ... 105% of nominal measuring range (FS)

Standard Settings

The transmitters have the following standard parameterisation:

- Current range: 4 mA ... 20 mA
- Measurement start: 4 mA = 0% of nominal measuring range (FS)
- Measurement end: 20 mA = 100% of nominal measuring range (FS)
- Damping: ~ 33 ms

Block Diagram / Electrical Connections

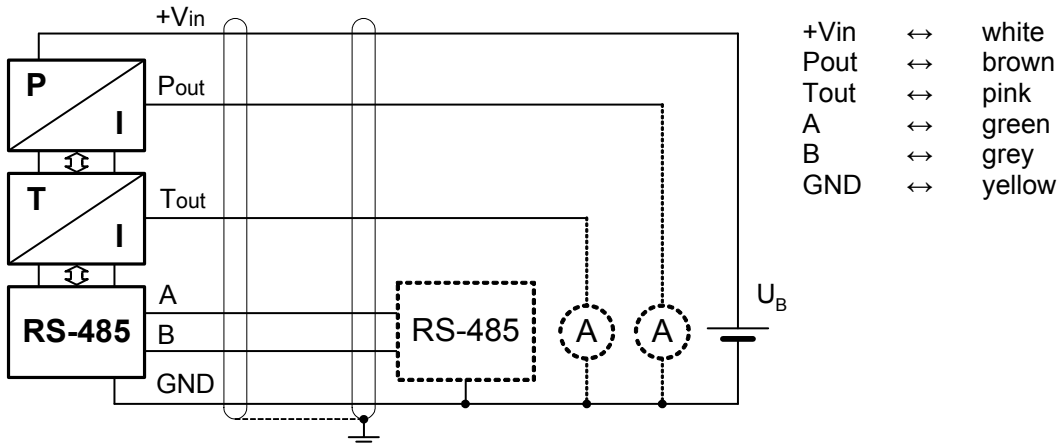

Cable Length

Several marginal conditions also contribute to determining the maximum cable length. Unlike 2-conductor transmitters, the maximum permitted resistance in the probe circuit can not be determined from one single formula. Depending on the application and mounting as well as the use of only digital or only analog or both output types, some of the criteria listed below have to be taken into consideration:

Minimum Supply Voltage

If the conductor resistance is concentrated and designated as R_W , the following simplified replacement diagram results for the static consideration of a probe (I_S is the supply current without load, R_R is the RS-485 terminal resistance, U_o is the amplitude of the signal voltage at the output of the RS-485 driver):

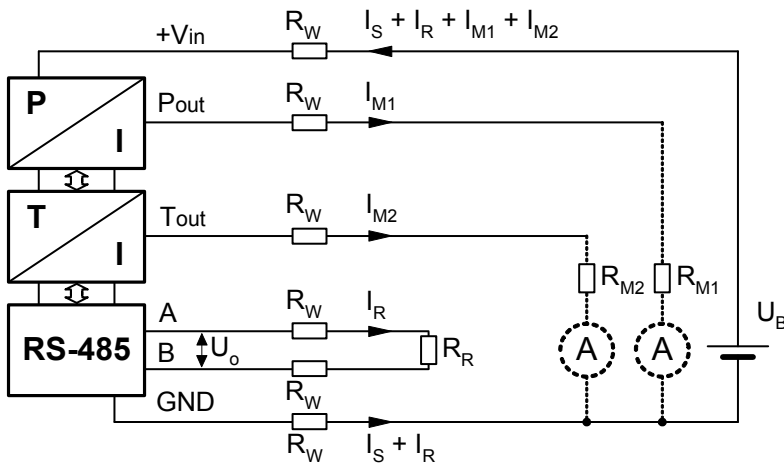

The following is valid as the result of voltage drop at the supply lines:

$$U_B \geq 2R_W \left(I_S + \frac{U_o}{2R_W + R_R} \right) + R_W (I_{M1max} + I_{M2max}) + V_{inmin}$$

At the same time however, the supply voltage must not be greater than the maximum supply voltage (30 V).

Maximum 4 ... 20 mA Load

In order that the output stages in the transmitter can still work properly, the load resistance ($R_W + R_{Mi}$) must not be greater than:

$$2R_W = U [V] - 6V/0.02A \quad 1 \text{ kOhm max.}$$

RS-485 Length Limit

The total length of an RS-485 bus must not be greater than 1.2 km [0.75 mile]. This length is the addition of the lengths of all RS-485 segments that are directly connected to one another.

To cover greater distances, RS-485 / RS-485 repeaters (such as Westermo RD-48 or Phoenix PSM-ME-RS485 / RS485-P) have to be installed.

RS-485 Common Mode Limit

The current flowing through the ground (GND) conductor (supply for the probes, bus current I_R as well as possible additional current components) causes a voltage drop between the probe GND and the GND of the receiver (the same as an PLC or a processing unit or an RS-485/RS-485 repeater) which, from the view of the RS-485, presents a common mode voltage. With RS-485, this voltage must never be greater than ± 7 V.

Analog Output Negative Limit

The current flowing through the ground (GND) conductor (supply for the probes, bus current I_R as well as possible additional current components) causes a voltage drop between the probe GND and the GND of the 20 mA current connection which, from the view of the probe, pulls the analog output into the negative. Even in the worst case (analog output = 4 mA), the output potential must not be less than 5 V below the probe GND.

Own Weight

If the cable is suspended as self-supporting, its own weight and the permitted tensile strength can present a length limit.

Note

- If the submersible transmitter is used at temperatures, where the medium can freeze over a longer time, we recommend the version with open protective cap. The version with open protective cap is recommended also in dirty water.
- In order to prevent destruction, the membrane must not be touched.
- The cable must not be tight bend or flat squeezed (because of the integrated pressure equalising pipe).
- Moisture must not be allowed to enter the pressure equalisation pipe. It is recommended that a junction box with dehumidifying agent is used.
- For applications in the field with extension cables having a cable length ≥ 5 m [16 ft] or inside a building with cable lengths ≥ 100 m [330 ft], a transmitter with the overvoltage protection option and an external overvoltage protection ASBG.48 or an junction box MPZAD2U.002 (at other end of the cable) must be used.
- The cable shield must be connected to a good ground potential.

- In order to compensate the long term drift an annual zero point alignment is recommended.
- If the accuracy option 0.05% FS is used, the RS-485 interface with 10'000 steps resolution (1 step = 0.01%) should be used, because the analogue output has only 4096 steps resolution (1 step = 0.024%).
- RS-485 Modbus networks with cable lengths > 100 m [330 ft] must be projected carefully (net topology, terminating resistor, type of cable, overvoltage protection).
- Conversion table for units of measurement used for pressure
(Value in new unit) = coefficient x (value in old unit)

Coefficient	New Unit						
	Old Unit	Pa = 1 N/m ²	bar	mWC	ftWC	mmHg (Torr)	psi
Pa = 1 N/m ²	1	10 ⁻⁵	1.02 x 10 ⁻⁴	3.35	7.5 x 10 ⁻³	1.45 x 10 ⁻⁴	1.02 x 10 ⁻⁵
bar	10 ⁵	1	10.2	33.5	750	14.5	1.02
mWC	9.81 x 10 ³	9.81 x 10 ⁻²	1	3.28	73.6	1.42	0.1
ftWC	2.99 x 10 ³	2.99 x 10 ⁻²	0.305	1	22.4	0.433	3.05 x 10 ⁻²
mmHg (Torr)	1.33 x 10 ²	1.33 x 10 ⁻³	1.36 x 10 ⁻²	4.46 x 10 ⁻²	1	1.93 x 10 ⁻²	1.36 x 10 ⁻³
psi	6.89 x 10 ³	6.89 x 10 ⁻²	0.703	2.31	51.7	1	7.03 x 10 ⁻²
kp/cm ² = at	9.81 x 10 ⁴	0.981	10	32.8	736	14.2	1

Example: 2 bar = ? psi:

bar = "old unit", psi = "new unit", ⇒ "coefficient" = 14.5

2 bar = 14.5 x 2 psi = 29 psi

Accessories

	Abbreviation	Order No.
Programming Kit consisting of interface box and Programming Software under Windows 9x / ME / NT / 2000 / XP	MPPKIT	0066900.001
Extension cable 6-wire, shielded (L in metres)	MPZVK6	04 60 106
Junction box for submersible sensor IP65 (~NEMA 6)	MPZAD.002	00 65 194.001
Junction box for submersible sensor IP65 (~NEMA 6), 2 OVP	MPZAD2U.002	00 65 192.001
Overvoltage protection AC/DC 48V	ASBG.48	00 32 721.003
Suspension arrangement for submersible probe	MPZHVT	00 65 717.001
Protection tube 2 m [6.6 ft] for pressure sensor (still water)	MPZSRR	00 65 720.001
Protection tube 2 m [6.6 ft] for pressure sensor (flowing water)	MPZSRF	00 65 721.001
Protection tube extension 2 m [6.6 ft] for MPZSRR, MPZSRF	MPZSRV	00 65 722.001
Sensor box for submersible probe	MPZFK	00 65 543.001
Protection tube for sensor cabinet	MPZSRU	00 65 549.001
Dehumidifier insert complete	MPZDES	00 65 191.001